

MASTERING THE MATH ON THE SAT



PHIL DONAUS

CHEIF OPERATING OFFICER | CAREER TRACK COORDINATOR



***10+ YEARS OF MATH TUTORING
EXPERIENCE***

***SPECIALIZE IN ALGEBRA
TRIGONOMETRY & CALCULUS***

CAREER TRACK COORDINATOR

OVERVIEW

1. ABOUT THE SAT MATH SECTION
2. STRATEGIES & TACTICS
3. QUICK MATHS PRACTICE
4. REVIEW & WAYS TO GET MORE HELP

ABOUT THE MATH

ABOUT THE MATH SECTION

SECTION	QUESTIONS	TIME
NO CALCULATOR	<i>15 MULTIPLE CHOICE, 5 GRID INS</i>	25 MINS
CALCULATOR	<i>30 MULTIPLE CHOICE, 8 GRID INS</i>	55 MINS

- LESS THAN 1 MINUTE PER QUESTION IN NO-CALCULATOR SECTION
- ABOUT 1MIN 30S PER QUESTION IN CALCULATOR SECTION

KNOW THE QUESTION TYPES

RATE & PROPORTION

RATIOS, UNIT RATES, SCALING, DISTASNCE, TIME, SPEED

ALGEBRA

SOLVE FOR X, FUNCTIONS, VARIABLES

GEOMETRY

LINES, GRAPHS, CIRCLES, TRIGONOMETRY

STATISTICS

PROBABILITY, AVERAGES, ANALYSIS

LOGIC

TRUTH TABLES, REASONING, CONDITIONAL STATEMENTS

TRICK QUESTIONS

TRICKY WORDING OR OBVIOUS ANSWERS

EXAMPLE - RATE & PROPORTION

If a car travels at a constant speed of 60 miles per hour, how far will it travel in 2.5 hours?

- A) 125 miles
- B) 140 miles
- C) 150 miles
- D) 165 miles
- E) 180 miles

EXAMPLE - ALGEBRA

The cost of using a telephone in a hotel meeting room is \$0.20 per minute. Which of the following equations represents the total cost c , in dollars, for h hours of phone use?

A) $c = 0.20(60h)$

B) $c = 0.20h + 60$

C) $c = \frac{60h}{0.20}$

D) $c = \frac{0.20h}{60}$

EXAMPLE - GEOMETRY

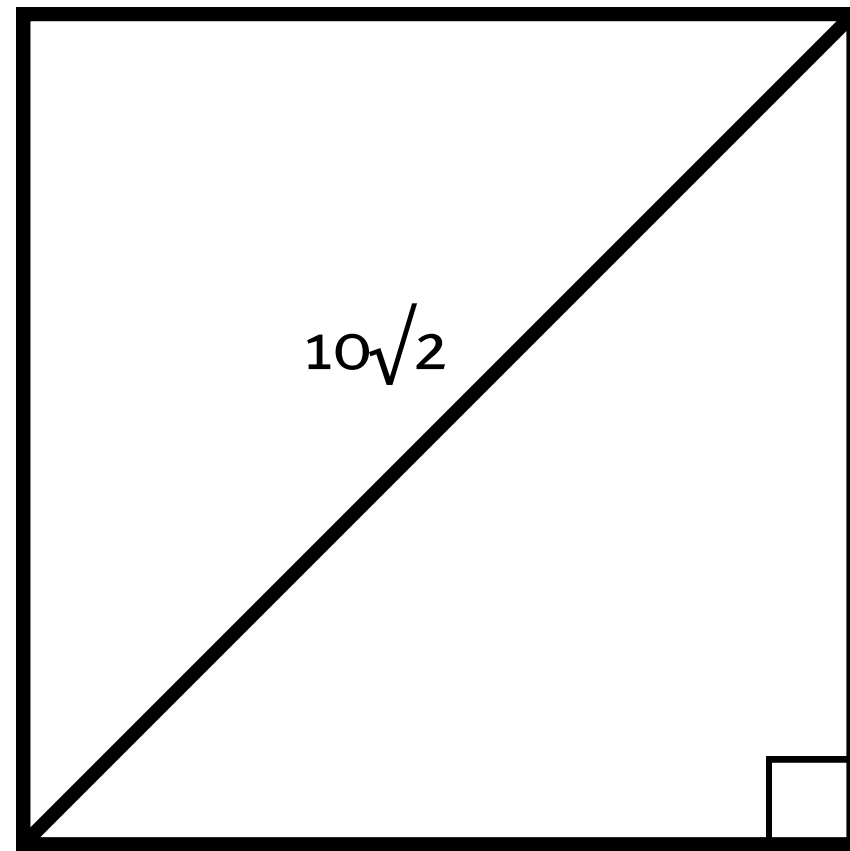

The diagonal of a square is $10\sqrt{2}$ units.
What is the side length of the square?

- A) 5 units
- B) $5\sqrt{2}$ units
- C) 10 units
- D) $10\sqrt{2}$ units
- E) 20 units

EXAMPLE - STATISTICS (1/2)

The average height of 5 students is 160 cm. If the heights of four students are 150 cm, 165 cm, 155 cm, and 170 cm, what is the height of the fifth student?

- A) 160 cm
- B) 165 cm
- C) 170 cm
- D) 175 cm
- E) 180 cm

EXAMPLE - STATISTICS (2/2)

A bag contains 3 red balls, 4 blue balls, and 5 green balls. If a ball is chosen at random, what is the probability of selecting a red ball?

- A) $1/3$
- B) $1/4$
- C) $3/12$
- D) $3/5$
- E) $4/12$

EXAMPLE - LOGIC

If the function f has five distinct zeros, which of the following could represent the complete graph of f in the xy -plane?

A)

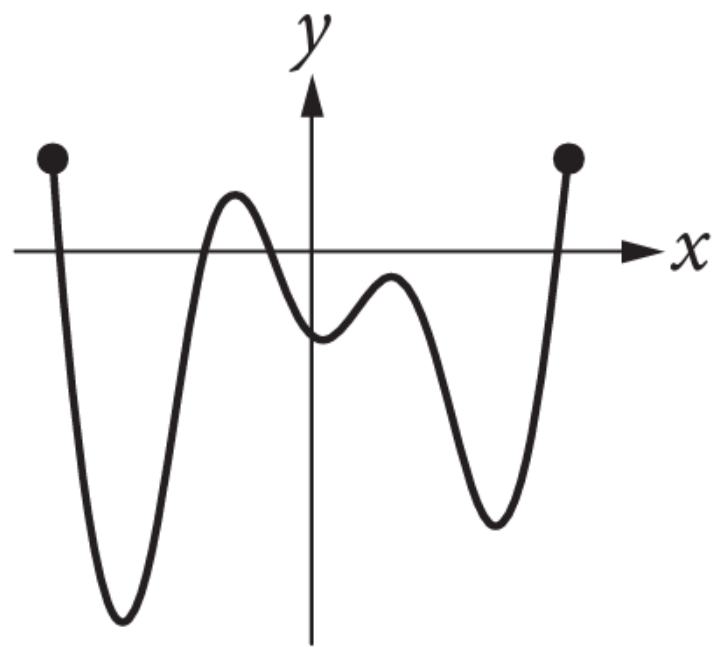

B)

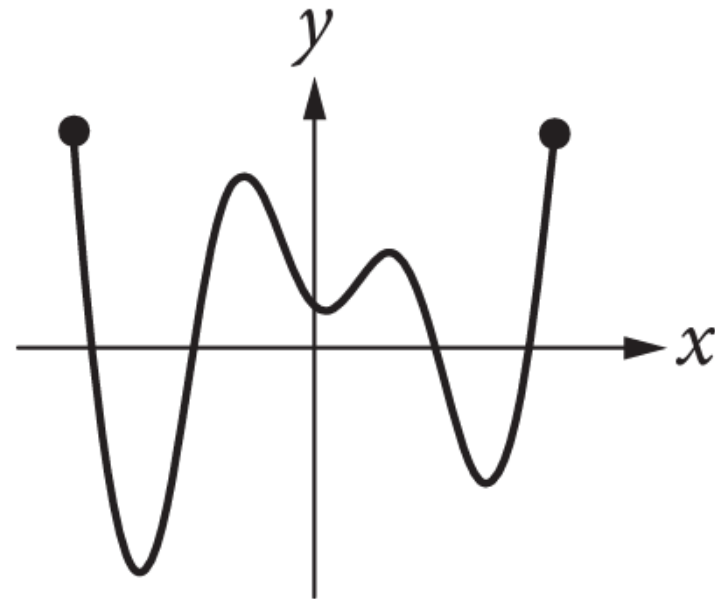

C)

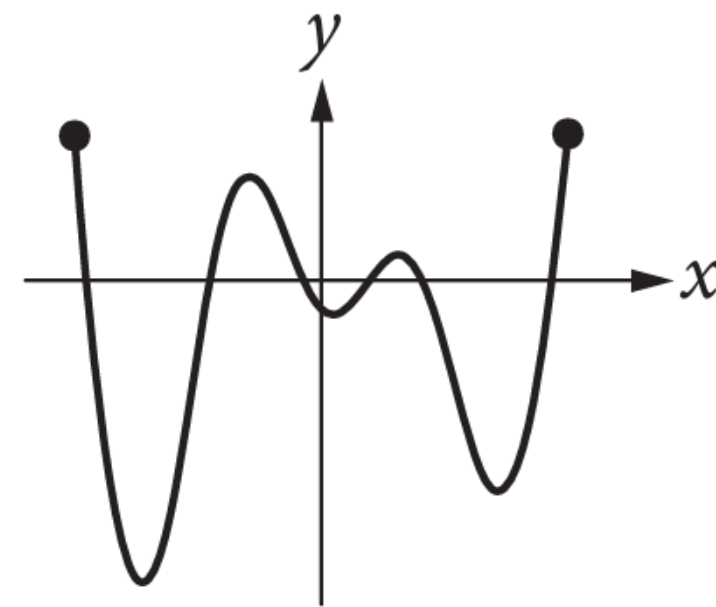

D)

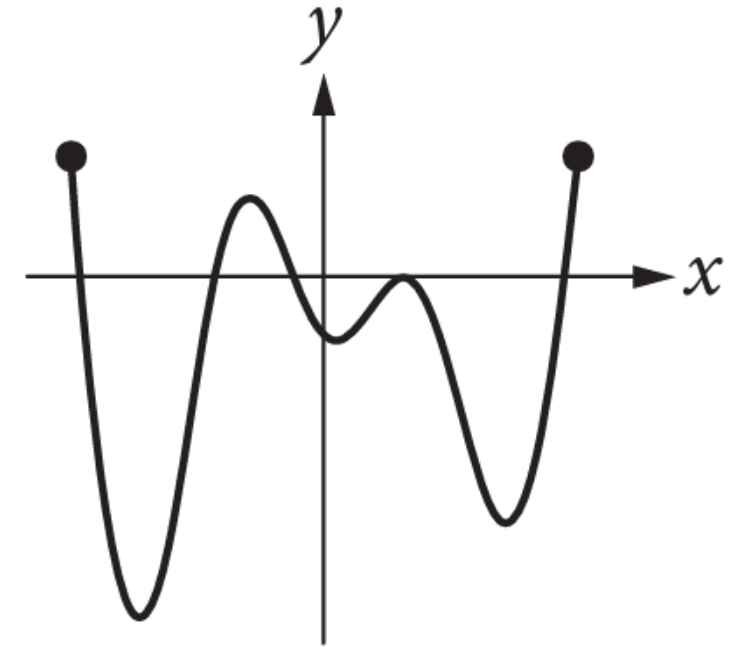

EXAMPLE - TRICK QUESTION

If a is a negative number, what is the value of a^2 ?

A) a

B) $-a$

C) $(-a)^2$

D) a^2

STRATEGIES & TACTICS

STRATEGIES

ANSWER THE EASY QUESTIONS FIRST

ELIMINATE WRONG ANSWERS

TACTICS

FILL IN EVERY QUESTION (GUESS IF NEEDED)

SKIP THE CALCULATOR (IT MAKES YOU SLOWER)

HOW TO TELL IF THE QUESTION IS EASY?

IDENTIFY THE TYPE OF QUESTION FIRST

UNPACK THE PARTS OF THE QUESTION

LOOK AT FAMILIAR GRAPHS AND DIAGRAMS

CHECK QUESTIONS FOR QUANTITY OR LANGUAGE RESPONSES

PLAY TO YOUR STRENGTHS AND AVOID QUESTIONS
YOU CANNOT QUICKLY MAKE SENSE OF

EXAMPLE - WHICH ONE IS EASIER?

$$3x^2 - 5x + 2$$

$$5x^2 - 2x - 6$$

Which of the following is the sum of the two polynomials shown above?

- A) $8x^2 - 7x - 4$
- B) $8x^2 + 7x - 4$
- C) $8x^4 - 7x^2 - 4$
- D) $8x^4 + 7x^2 - 4$

n	1	2	3	4
$f(n)$	-2	1	4	7

The table above shows some values of the linear function f . Which of the following defines f ?

- A) $f(n) = n - 3$
- B) $f(n) = 2n - 4$
- C) $f(n) = 3n - 5$
- D) $f(n) = 4n - 6$

HOW DO I USE PROCESS OF ELIMINATION TO MY BENEFIT?

1. LOOK FOR INCONSISTENCIES IN THE MULTIPLE CHOICE OPTIONS
 2. IDENTIFY WHICH OPTIONS WOULD BE CONSIDERED IMPOSSIBLE
 3. LOOK AT OUTLIER RECORDS
-

YOU CAN ALSO USE DEDUCTION TO HELP WITH THE OPEN ANSWER QUESTIONS OR "BUBBLE INS"

EXAMPLE - PROCESS OF ELIMINATION

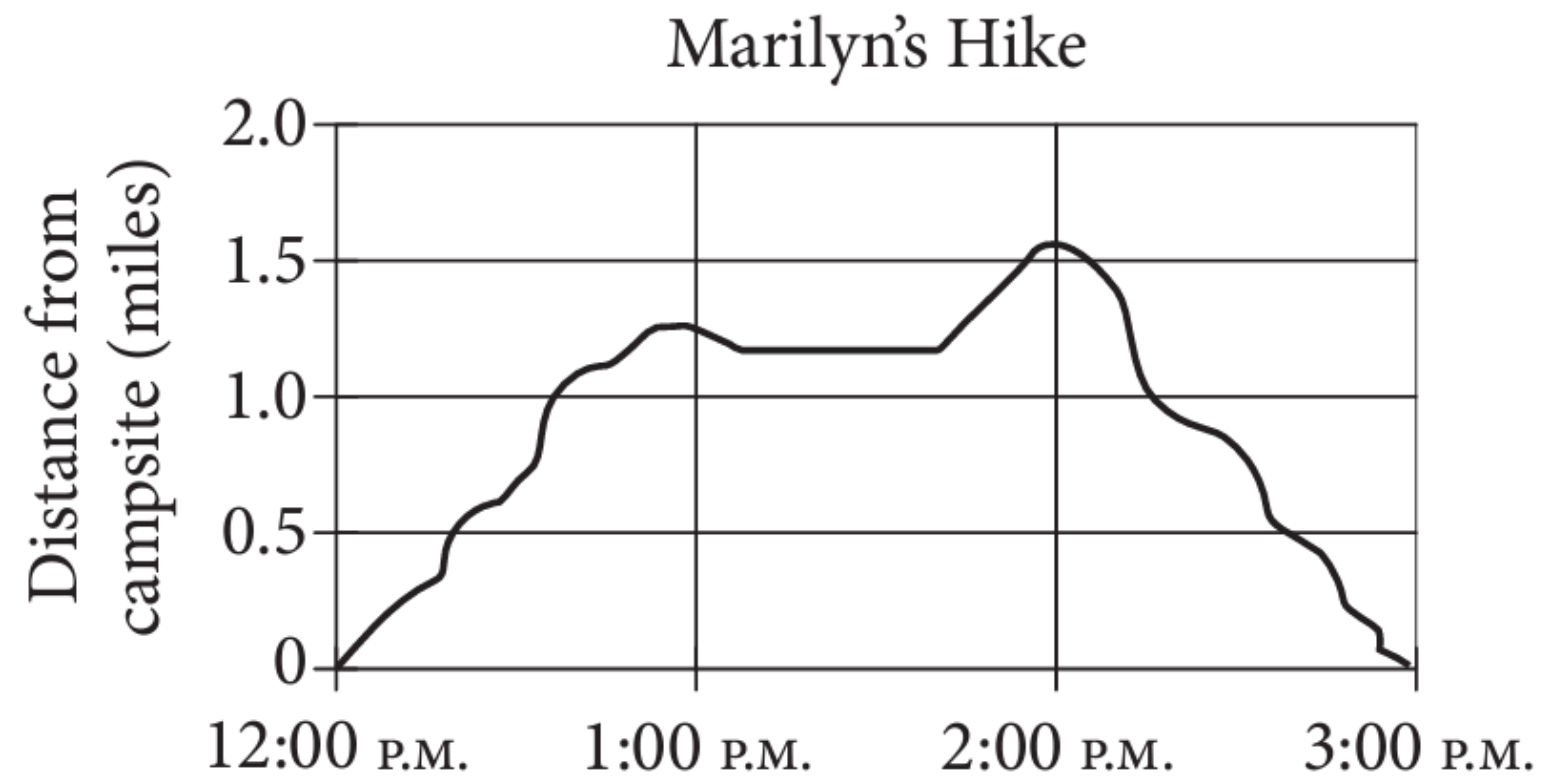

The graph above shows Marilyn's distance from her campsite during a 3-hour hike. She stopped for 30 minutes during her hike to have lunch. Based on the graph, which of the following is closest to the time she finished lunch and continued her hike?

- A) 12:40 P.M.
- B) 1:10 P.M.
- C) 1:40 P.M.
- D) 2:00 P.M.

QUICK MATHS PRACTICE

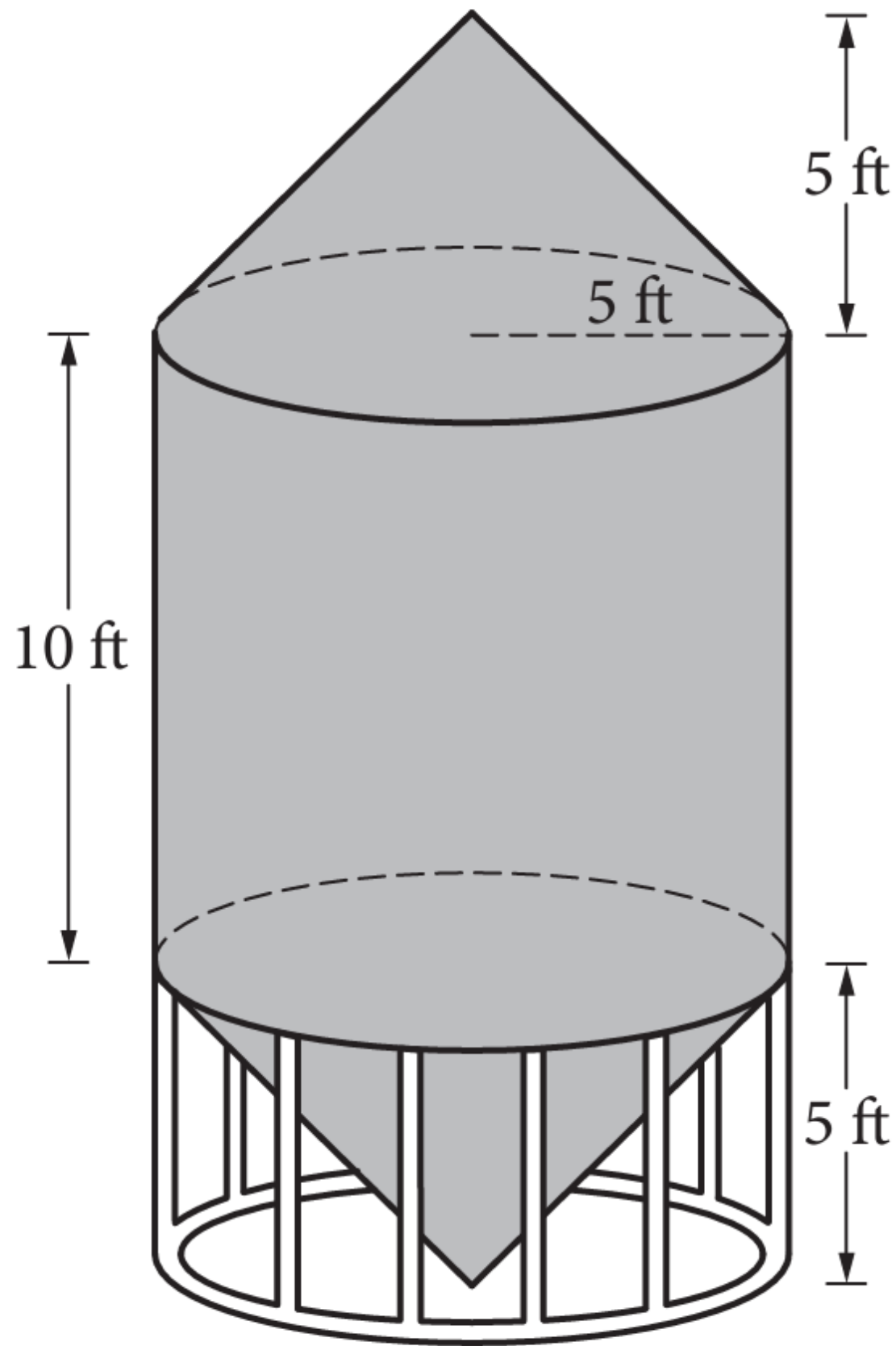

A grain silo is built from two right circular cones and a right circular cylinder with internal measurements represented by the figure above. Of the following, which is closest to the volume of the grain silo, in cubic feet?

- A) 261.8
- B) 785.4
- C) 916.3
- D) 1,047.2

46

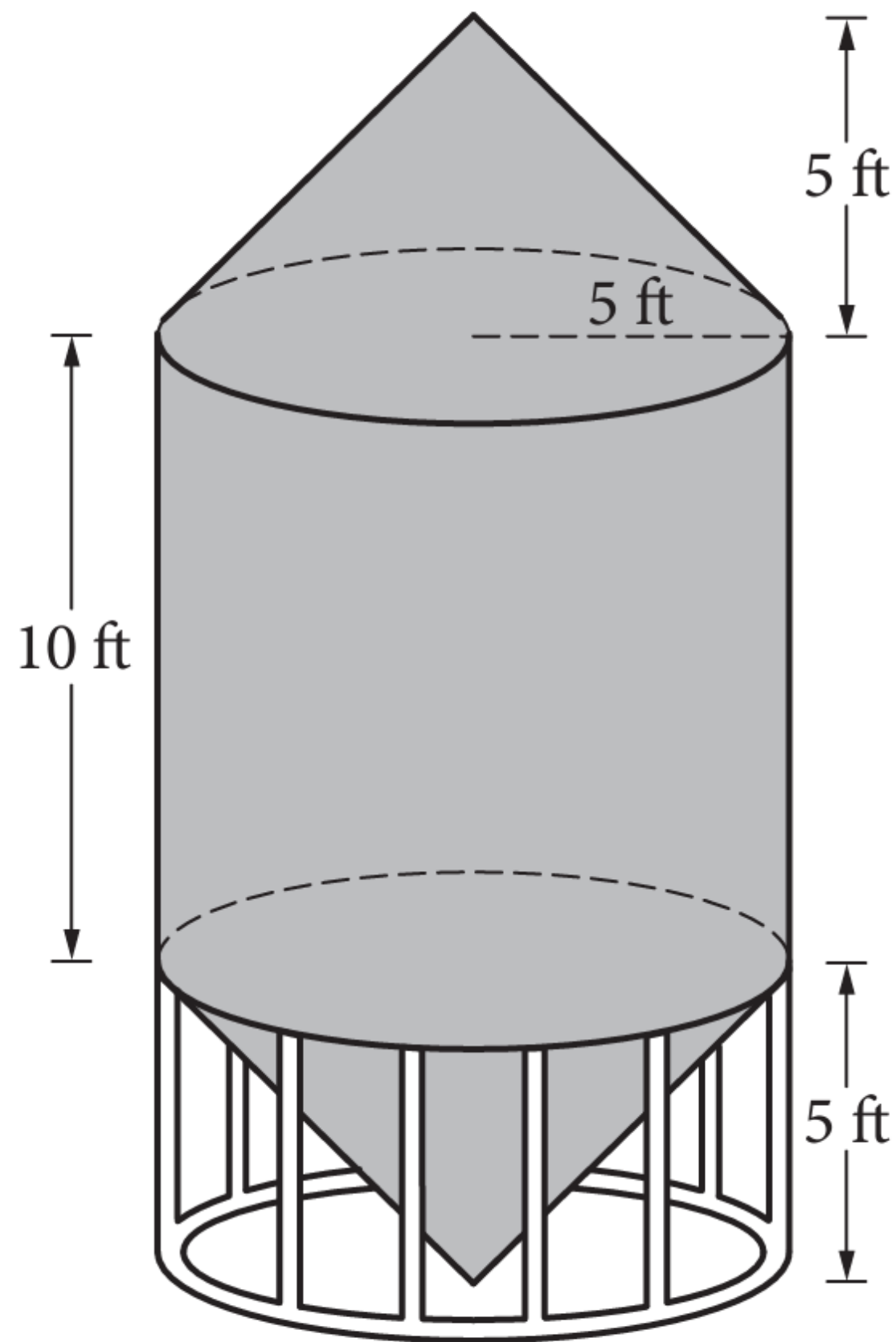

A grain silo is built from two right circular cones and a right circular cylinder with internal measurements represented by the figure above. Of the following, which is closest to the volume of the grain silo, in cubic feet?

- A) 261.8
- B) 785.4
- C) 916.3
- D) 1,047.2

CATEGORY	GEOMETRY
ANSWER	C

In triangle ABC, if angle A = 45 degrees, angle B = 60 degrees, what is the measure of angle C?

A) 45 degrees

B) 60 degrees

C) 75 degrees

D) 90 degrees

In triangle ABC, if angle A = 45 degrees, angle B = 60 degrees, what is the measure of angle C?

A) 45 degrees

B) 60 degrees

C) 75 degrees

D) 90 degrees

CATEGORY	GEOMETRY
ANSWER	C

The average of a set of 5 numbers is 18. If four of the numbers are 15, 20, 18, and 25, what is the fifth number?

A) 12

B) 15

C) 18

D) 22

The average of a set of 5 numbers is 18. If four of the numbers are 15, 20, 18, and 25, what is the fifth number?

A) 12

B) 15

C) 18

D) 22

CATEGORY	STATS
ANSWER	A

The ratio of apples to oranges in a basket is 3:2. If there are 20 fruits in the basket, how many apples are there?

A) 9

B) 10

C) 12

D) 13

The ratio of apples to oranges in a basket is 3:2. If there are 20 fruits in the basket, how many apples are there?

A) 9

B) 10

C) 12

D) 13

CATEGORY	RATE & PROP
ANSWER	C

Factor the expression: $4x^2 - 16$

A) $(2x + 4)(2x - 4)$

B) $(4x + 2)(x - 2)$

C) $(2x + 2)(2x - 2)$

D) $(2x - 2)(2x - 2)$

E) $(x + 2)(x - 2)$

Factor the expression: $4x^2 - 16$

A) $(2x + 4)(2x - 4)$

B) $(4x + 2)(x - 2)$

C) $(2x + 2)(2x - 2)$

D) $(2x - 2)(2x - 2)$

E) $(x + 2)(x - 2)$

CATEGORY

ALGEBRA

ANSWER

A

Consider the statement: "If x is an even number, then $x + 2$ is also an even number." Which statement below is false?

A) All even numbers are divisible by 2

B) $x + 2$ will always be an even number.

C) If x is an odd number, then $x - 2$ is an odd number.

D) If x is an even number, then $x - 2$ is an even number.

Consider the statement: "If x is an even number, then $x + 2$ is also an even number." Which statement below is false?

A) All even numbers are divisible by 2

B) $x + 2$ will always be an even number.

C) If x is an odd number, then $x - 2$ is an odd number.

D) If x is an even number, then $x - 2$ is an even number.

CATEGORY	LOGIC
ANSWER	B

Mr. Kohl has a beaker containing n milliliters of solution to distribute to the students in his chemistry class. If he gives each student 3 milliliters of solution, he will have 5 milliliters left over. In order to give each student 4 milliliters of solution, he will need an additional 21 milliliters. How many students are in the class?

- A) 16
- B) 21
- C) 23
- D) 26

Mr. Kohl has a beaker containing n milliliters of solution to distribute to the students in his chemistry class. If he gives each student 3 milliliters of solution, he will have 5 milliliters left over. In order to give each student 4 milliliters of solution, he will need an additional 21 milliliters. How many students are in the class?

- A) 16
- B) 21
- C) 23
- D) 26

CATEGORY	ALGEBRA
ANSWER	D) 26

In the xy -plane, the line determined by the points $(2, k)$ and $(k, 32)$ passes through the origin. Which of the following could be the value of k ?

- A) 0
- B) 4
- C) 8
- D) 16

In the xy -plane, the line determined by the points $(2, k)$ and $(k, 32)$ passes through the origin. Which of the following could be the value of k ?

- A) 0
- B) 4
- C) 8
- D) 16

CATEGORY	ALGEBRA
ANSWER	C) 8

A rectangle was altered by increasing its length by 10 percent and decreasing its width by p percent. If these alterations decreased the area of the rectangle by 12 percent, what is the value of p ?

- A) 12
- B) 15
- C) 20
- D) 22

A rectangle was altered by increasing its length by 10 percent and decreasing its width by p percent. If these alterations decreased the area of the rectangle by 12 percent, what is the value of p ?

- A) 12
- B) 15
- C) 20
- D) 22

CATEGORY	ALGEBRA
ANSWER	D) 22

A rectangle was altered by increasing its length by 10 percent and decreasing its width by p percent. If these alterations decreased the area of the rectangle by 12 percent, what is the value of p ?

- A) 12
- B) 15
- C) 20
- D) 22

A rectangle was altered by increasing its length by 10 percent and decreasing its width by p percent. If these alterations decreased the area of the rectangle by 12 percent, what is the value of p ?

- A) 12
- B) 15
- C) 20
- D) 22

CATEGORY	ALGEBRA
ANSWER	D) 26

LET'S REVIEW

REVIEW & KEY TAKEAWAYS

- UNDERSTAND THE TYPE OF QUESTION IS BEING ASKED
- ANSWER THE QUESTIONS THAT PLAY TO YOUR STRENGTHS FIRST
- ELIMINATE OBVIOUSLY WRONG ANSWERS FIRST
- NEVER LEAVE A QUESTION BLANK
- TREAT THE CALCULATOR AS A LAST RESORT

REVIEW & KEY TAKEAWAYS

- UNDERSTAND THE TYPE OF QUESTION IS BEING ASKED
- ANSWER THE QUESTIONS THAT PLAY TO YOUR STRENGTHS FIRST
- ELIMINATE OBVIOUSLY WRONG ANSWERS FIRST
- NEVER LEAVE A QUESTION BLANK
- TREAT THE CALCULATOR AS A LAST RESORT

